



RFID SECURE DOOR LOCK SYSTEM

Vivek Ku Dhal, GIET University, 22ece122.vivekkumardhal@giet.edu

Mahesh Sabar, GIET University, 22ece126.maheshsabar@giet.edu

Kashinath Giri, GIET University, 22ece116.kashinathgiri@giet.edu

Ramkrishna Jena, GIET University, 22ece117.ramkrisnajena@giet.edu

Abstract: This project explores the implementation of an RFID-based digital security system designed for restricted access zones, ensuring that only authorized personnel can enter. Utilizing Radio Frequency Identification (RFID) technology, this system features a digital door-locking mechanism governed by an RFID reader that authenticates users and grants automatic entry. The system not only facilitates quick and secure check-in and check-out processes but also maintains a comprehensive record of user access. By requiring users to present an RFID tag, which contains unique identification information, the system verifies credentials against a stored database. The use of passive RFID technology, which is cost-effective and compact, enhances the overall design, as these tags derive power from the reader, eliminating the need for batteries. Upon proximity detection, the reader captures and transmits the tag information to authorize or deny access. This study demonstrates the effectiveness of RFID in enhancing security and operational efficiency, providing a reliable solution for controlled access in various environments.

Keywords— RFID technology, digital security system, restricted access zones, passive RFID tag

1. Introduction:

Access control systems are designed to restrict unauthorized individuals from entering secure areas, such as buildings or offices. Traditionally, access control relied on mechanical methods like deadbolts, padlocks, and brass keys. However, these methods have proven inadequate due to their vulnerability to break-ins. In recent years, electronic access control systems, powered by computer-based technologies, have emerged as a more secure and efficient alternative. One such technology is Radio Frequency Identification (RFID), which offers a fast and reliable method for granting access to authorized individuals while maintaining a record of user activity. This study explores the implementation of RFID technology in a digital door locking system, demonstrating its effectiveness in enhancing security and convenience. Radio Frequency Identification (RFID) is a groundbreaking technology that has reshaped the landscape of data transmission and identification. Emerging as a fundamental tool for automatic identification, RFID allows for the wireless transfer of information between a reader and a tag, which can be attached to or embedded in an object, location, or individual. At its core, RFID operates on the principle of utilizing radio waves to communicate, providing a fast and efficient means of tracking and managing assets,

people, and processes across various sectors. Despite its significant potential, RFID technology faced initial challenges in widespread adoption, primarily due to a lack of standardization among manufacturers. This fragmentation created barriers to implementation, as businesses were hesitant to invest in a technology that lacked universally accepted protocols. However, as the technology has matured, the benefits of RFID have become increasingly clear. Today, RFID is recognized for its superior efficiency, accuracy, and security compared to traditional identification methods, making it an indispensable tool in industries ranging from retail and logistics to healthcare and security. An RFID system is not merely a collection of components; it is a comprehensive solution comprising three essential elements- the RFID tag , the reader , and the back-end application system, often integrated with a database. Together, these components work seamlessly to facilitate automatic identification and data management. The RFID tag, which contains a unique identifier, can be passive, active, or semi-passive, depending on its power source and functionality. The reader scans for these tags and transmits their information to the application system, which manages data processing, transactions, and record maintenance. One of the most practical applications of RFID technology is in digital door locking systems. By employing an RFID reader, these systems offer a modern solution for user authentication and access control. When a user presents their RFID tag near the reader, the system verifies their identity against the stored data, unlocking the door if the credentials match. This method not only streamlines access but also enhances security by maintaining a detailed log of user activity, ensuring that only authorized individuals can enter restricted areas. As security concerns continue to rise, the importance of effective user authentication cannot be overstated. RFID technology provides a reliable and efficient means to address these needs, allowing for quick and convenient access while safeguarding sensitive spaces. With advancements in RFID technology and growing standardization efforts, its applications are expanding rapidly, paving the way for innovative solutions that improve operational efficiency and security across various industries. In summary, RFID technology represents a significant leap forward in the realm of identification and access control, offering a versatile and powerful tool for modern security needs.

2. Literature review:

In the work by Gyanendra K Verma and Pawan Tripathi “A digital security system with door lock system using rfid technology” in this paper they discuss about A digital door locking system can be managed with an RFID reader. It scans RFID tags, captures the unique identifier, and verifies it against a database of authorized users. If it matches, the system unlocks the door automatically.[2]Another work by Chijioke Nwogu, Monday Eze, Charles Okunbor “Design and implementation of access door control with mobile alert” in this paper they discussed about a two-level security system that

uses both a password (or code) and a fingerprint. The system ensures that only authorized individuals can access the secured apartment or office. Access is granted only after the system verifies both the password and the fingerprint.[3]Another suggested paper is Shrinidhi Gindi, Naiyer Shaikh, Kashif Beig, Abdeali Sabuwala “smart lock system using RFID” This paper presents a smart lock system, an innovative access control solution that leverages IoT technology and includes online monitoring. The smart lock system automates access control, enhancing security and providing property owners with peace of mind.[4]Shubham Soni, Rajni Soni, Akhilesh A. Wao “RFID-Based Digital Door Locking System” in this paper they discussed about Using the Arduino UNO microcontroller in this project simplifies the design, allowing it to be completed more quickly than with previously used technologies. Additionally, this door lock system is highly secure and records the information of individuals entering and exiting.[5]Akter Prity, Jannatul Afrose, Md. Mahmudul Hasan “RFID Based Smart Door Lock Security System” In this paper, they attempt to create a secure door lock system that offers effective security measures and is easily accessible for users, the components used can be swapped with similar types without significantly altering the program. This allows the system to achieve the same functionality in a more compact form.[6]Ni Ni San Hlaing, San San Lwin “Electronic door lock using RFID and Password based on Arduino” this paper presents a system where they have developed an electronic door lock system using RFID and password based on Arduino UNO it uses RFID and keypad. When the RFID reader reads the rfid card if the user is registered, Arduino permits to press password keypad it can be used for wide range of application and Arduino used for more cost effectiveness[7]Mardianus, Andi Yusika Rangan, Salmon “Prototype Smart Security on Doors using RFID with Telegram Monitor NodeMCU Based” in this paper they have built a smart security prototype at the door using RFID with telegram monitor they have used nodemcu ESP 12E as main hardware RFID MFRC522 as reader based on the results they have produced the smart security prototype can function properly and also sent notifications regarding the access of doors.[8]Sukeshini Tabhane, Prathamesh Kadam, Mahendra Govari, Harsh Chavan, Ulhas Kotkar “Smart Door Lock System Using ESP32” here they have made an IoT-based smart door lock which enhance home security by enabling remote monitoring and control. Sensors like PIR and touch detect motion and interaction, while ESP32 CAM provides visitor images for verification. Protocols like MQTT ensure efficient communication, and apps like Blynk streamline alerts and control, improving convenience and safety. [9]Syahri Ramadhani, Dhanny Permatasari Putri “Design of a Home Door Security System Based on NodeMCU ESP32 Using a Magnetic Reed Switch Sensor and Telegram Bot Application” here they have used IoT which enhances security by enabling real-time monitoring and control of devices. RFID technology ensures secure access by granting entry only to registered users. Telegram Bot adds convenience by providing remote door control and real-time notifications, improving response to security events.

3. Design:

In this RFID-based door lock system, the RFID reader continuously emits a low-power electromagnetic field, enabling it to detect RFID tags within its range. When an RFID tag, typically a passive one, comes close to the reader, it gets powered by this electromagnetic field and activates. The tag then sends its unique identification code back to the reader. The reader receives this code and transmits it to the microcontroller. The microcontroller holds a stored list of authorized IDs and uses this list to check the received code. If the tag's ID matches one on the authorized list, it's considered valid, and the microcontroller sends a signal to unlock the electronic door lock. The door remains unlocked for a short period before automatically re-locking to maintain security. However, if the tag's ID doesn't match any on the authorized list, the microcontroller keeps the lock engaged, preventing entry. The system resets after each attempt, allowing the RFID reader to continuously scan for other tags in real-time. Some advanced systems might log each access attempt, recording details such as the time of access and whether the attempt was authorized. This log could be stored locally in the microcontroller's memory or sent to a remote server for monitoring purposes. Further, the system could support remote control and updates through Wi-Fi or Bluetooth, enabling administrators to manage authorized IDs, monitor access activity, or unlock the door remotely if needed. In setups where power efficiency is important, such as battery-operated systems, the RFID reader might operate in a low-power mode, only activating when motion or presence is detected to conserve energy. This design creates a secure, efficient, and user-friendly access control system with reliable feedback for users and strong control over authorized access.

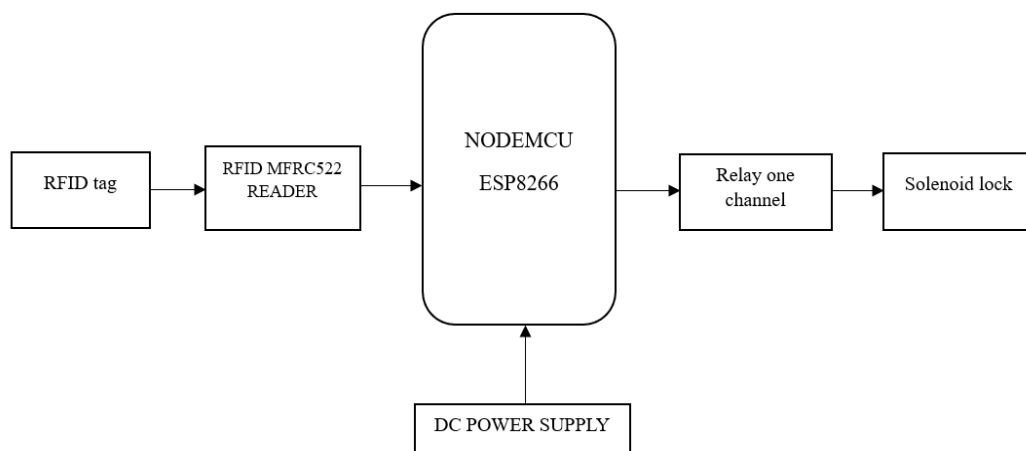

Figure 1: Block Diagram of RFID Door Lock System

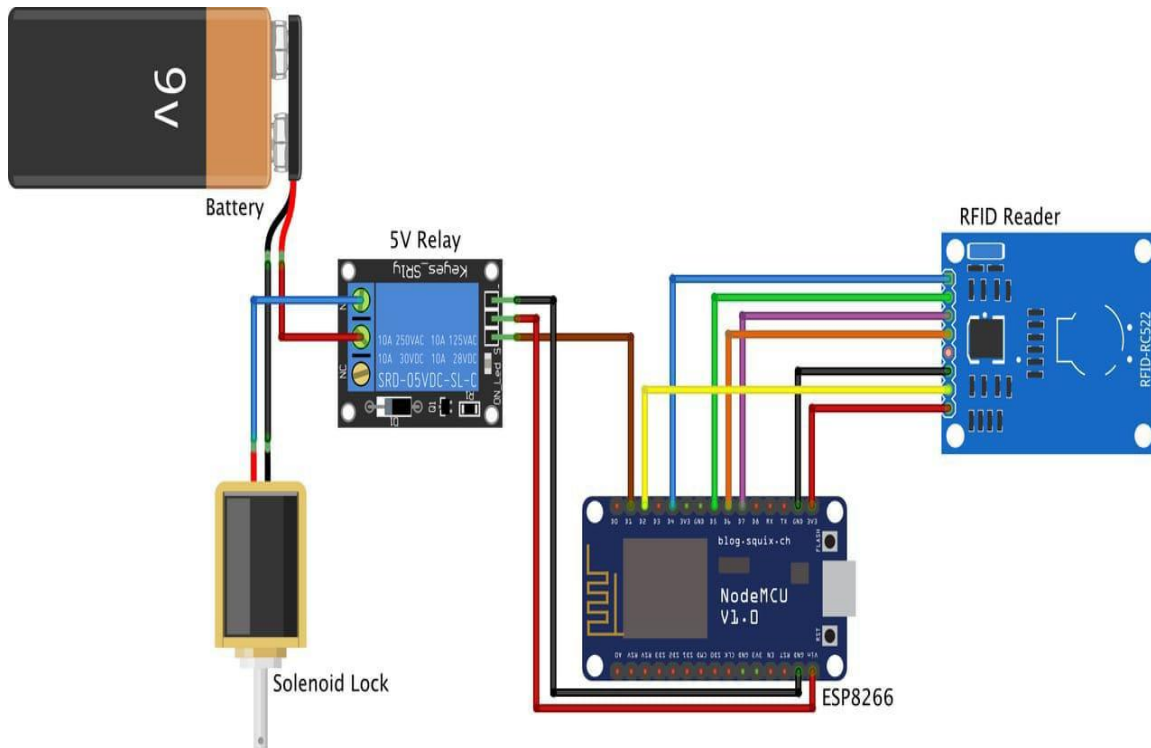

Figure 2: Rfid Door Lock System

4. Simulation Parameter:

COMPONENT	SPECIFICATION	QUANTITY
NODEMCU ESP8266	3.3V	1
RFID MFRC522 READER	13.56MHz	1
SOLENOID LOCK	12V	1
RELAY ONE CHANNEL	3.3V-5V	1
BREAD BOARD	-	1
BATTERY	12V	1

Figure 3: User log table

5. Result Analysis:

In this RFID-based access control system, the RFID reader continuously emits a low-power electromagnetic field to detect RFID tags within its range. When a passive RFID tag comes close, it gets powered by this field and activates, sending its unique identification code to the reader. The reader then transmits this code to the microcontroller, which holds a stored list of authorized IDs. The microcontroller checks the received code against this list. If the tag's ID matches one on the authorized list, the microcontroller sends a signal to unlock the electronic door lock. The door remains unlocked for a short period before automatically re-locking to maintain security. If the tag's ID doesn't match any on the authorized list, the microcontroller keeps the lock engaged, preventing entry. The system resets after each attempt, allowing the RFID reader to continuously scan for other tags in real-time. Some advanced systems might log each access attempt, recording details such as the time of access and whether the attempt was authorized. This log could be stored locally in the microcontroller's memory or sent to a remote server for monitoring purposes. Additionally, the system could support remote control and updates through Wi-Fi or Bluetooth, enabling administrators to manage authorized IDs, monitor access activity, or unlock the door remotely if needed. In setups where power efficiency is important, such as battery-operated systems, the RFID reader might operate in a low-power mode, only activating when motion or presence is detected to conserve energy. This design creates a secure, efficient, and user-friendly access control system with reliable feedback for users and strong control over authorized access .

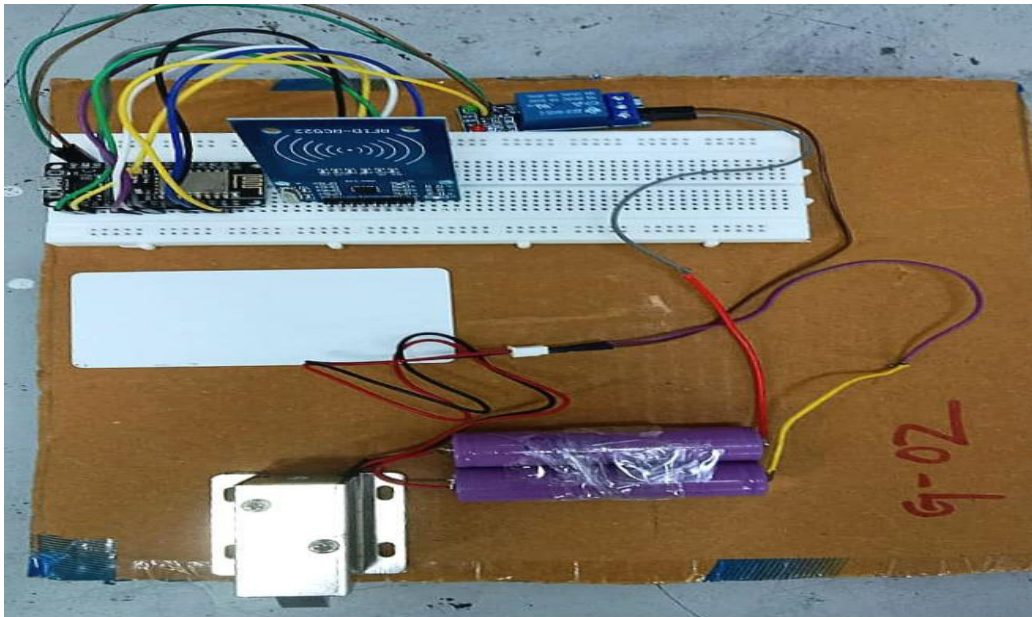

Figure 4: Practical Circuit



6. Conclusion:

This project demonstrates a secure and efficient RFID-based door lock using NodeMCU. By leveraging RFID technology, the system provides reliable access control that is easy to use and manage. NodeMCU's Wi-Fi capabilities allow for potential upgrades, such as remote monitoring or access control via a mobile application. The system integrates IoT and embedded systems to enhance security in homes and offices. It meets the basic requirements of an access control system and offers flexibility for further enhancements, making it a scalable and robust solution for modern access control needs. The RFID reader emits a low-power electromagnetic field to detect RFID tags within its range. When a passive RFID tag comes close, it gets powered by this field and activates, sending its unique identification code to the reader. The reader transmits this code to the NodeMCU, which checks it against a list of authorized IDs. If the ID matches, the NodeMCU unlocks the electronic door lock for a short period before re-locking. If the ID is not authorized, the lock remains engaged. The system resets after each attempt, continuously scanning for other tags. Advanced systems might log access attempts, support remote control via Wi-Fi or Bluetooth, and operate in low-power mode to conserve energy. This design ensures a secure, efficient, and user-friendly access control system.

7. Reference:

1. Gyanendra K Verma and Pawan Tripathi “A digital security system with door lock system using rfid technology” International Journal of Computer Applications (0975 – 8887) Volume 5– No.11, August 2010
2. Chijioke Nwogu, Monday Eze, Charles Okunbor “Design and implementation of access door control with mobile alert” International Journal of Engineering & Technology, 9 (2) (2020) 480-486.
3. Shrinidhi Gindi, Naiyer Shaikh, Kashif Beig, Abdeali Sabuwala “smart lock system using RFID” International Research Journal of Engineering and Technology (IRJET) e-ISSN: 2395-0056 Volume: 07 Issue: 07 | July 2020.
4. Shubham Soni, Rajni Soni, Akhilesh A. Wao “RFID-Based Digital Door Locking System” Indian Journal of Microprocessors and Microcontroller (IJMM) ISSN: 2582-8835 (Online), Volume-1 Issue-2, September 2021.
5. Akter Prity, Jannatul Afrose, Md. Mahmudul Hasan “RFID Based Smart Door Lock Security System” American Journal of Sciences and Engineering Research E-ISSN - 2348 -703X, Volume 4, Issue 3, 2021.
6. Sujita B. Dabekar, Sandhyarani A. Lahade, Manasi S. Lunge, Prof. Deepali Yewale “IOT Based Smart Door Locked System Using NodeMCU” International Journal for Research in Applied Science & Engineering Technology (IJRASET) ISSN: 2321-



- 9653; IC Value: 45.98; SJ Impact Factor: 7.538 Volume 10 Issue VII July 2022- Available at www.ijraset.com
7. M S Z M Zabidi, K H Yusof1, A S Ahmad1, N H Shahadan, K A Yusof, K Amri Yusof, and S N M Subari “IoT RFID Lock Door Security System” M S Z M Zabidi et al 2022 J. Phys.: Conf. Ser. 2312 012092.
 8. Sampa Das, Shibam Gupta “Door Lock System by RFID Using Arduino” International Journal of Science and Research (IJSR) ISSN: 2319-7064 SJIF (2022): 7.942.
 9. Zhang, L., “An Improved Approach to Security and Privacy of RFID application System”, Wireless Communications, Networking and Mobile Computing. International Conference. pp 1195- 1198, 2005.
 10. Goodrum, P., McLaren, M., Durfee, A.,” The application of active radio frequency identification technology for tool tracking on construction job sites.” Automation in Construction, 15 (3), 2006, pp 292-302.
 11. Leo, A., & Aziz, A. (2021). Design of an Automatic Door Lock System Using Rfid Arduino Uno. Ampere Journal, 6 (1), 43-48.
 12. M. H. Assaf, R. Mootoo, S. R. Das, E. M. Petriu, V. Groza and S. Biswas, "Sensor based home automation and security system," Instrumentation and Measurement Technology Conference (I2MTC), 2012 IEEE International, Graz, 2012, pp. 722-727. doi: 10.1109/I2MTC.2012.6229153.
 13. Anshul Maurya, Anuj Saini, Ayush Pawar, Dipesh Singh, Tanuj Rawat “ADVANCED RFID BASED DOOR LOCK SYSTEM AND DIGIT COUNTER” Volume:04/Issue:05/May2022 Impact Factor- 6.752 www.irjmets.com.
 14. Ni Ni Sanhlaing ,San San Iwin “Electronic Door Lock using RFID and Password Based on Arduino “International Journal of Trend in Scientific Research and Development (IJTSRD) Volume: 3 | Issue: 3 | Mar-Apr 2019 Available Online: www.ijtsrd.com e-ISSN: 2456 – 6470.
 15. Mardianus, Andi Yusika Rangan, Salmon “Prototype Smart Security on Doors using RFID with Telegram Monitor NodeMCU Based” TEPIAN Vol. 2 No. 1 (March 2021) p-ISSN 2721-5350 eISSN27215doi.org/10.51967/tepian.v2i1.293 © 2021 TEPIAN Agricultural Polytechnic of Samarinda.